



**Rising
8th**

**Summer
Enrichment Packet**

Summer Science Enrichment Packet

Rising 8th Graders

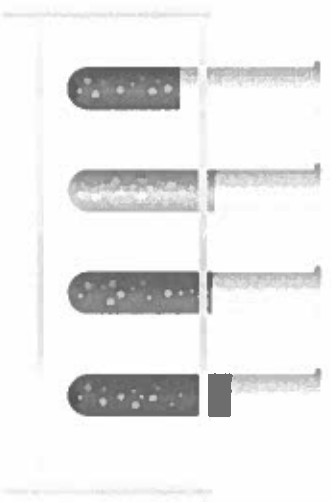

DUBOIS INTEGRITY ACADEMY

Name:

Monday	Tuesday
<p>Label the Parts of Speech of the underlined words. <i>N = Noun, V = Verb, PN= Pronoun, Adj = Adjective, Adv = Adverb, P = Preposition C= Conjunction</i></p> <p>My <u>friends</u> <u>and</u> I like riding the carousel at the <u>fair</u>.</p>	<p>Label the Parts of Speech of the underlined words.</p> <p><u>We</u> eat <u>cold</u> ice cream <u>on</u> a hot day.</p>
<p>Which figurative language device means a comparison that uses the words like, as, or than?</p>	<p>Circle the simile in this sentence.</p> <p>The other team's quarterback is as big as a redwood tree.</p>
<p>Circle the pronoun. Underline its antecedent.</p> <p>Jax will pay for his lunch with cash today.</p>	<p>Cross out and correct the ambiguous pronoun.</p> <p>They told me I could ride the bus home with my friend.</p>
<p>Add comma(s) where needed, if needed.</p> <p>The florist's eldest daughter Lilly smelled the rose.</p>	<p>Add comma(s) where needed, if needed.</p> <p>My birthday October 31 2005 is on Halloween.</p>
<p>Which word in this sentence is misspelled?</p> <p>The boys over their are playing for our team.</p>	<p>Which word in this sentence is misspelled?</p> <p>We will have a party just in time for there birthday.</p>
<p>Write a simple sentence.</p>	<p>Turn your simple sentence into a compound sentence.</p>
<p>Write the meaning of the root bell.</p>	<p>Write a sentence using a word with the root bell.</p>

Name:

Weekly Language Review – G7.Q1.W1

Wednesday	Thursday
<p>Circle the subject, and underline the verb.</p> <p>My friends and I like riding the carousel at the fair.</p>	<p>Circle the subject, and underline the verb.</p> <p>We eat cold ice cream on a hot day.</p>
<p>Explain the figurative language in yesterday's sentence.</p>	<p>Write a sentence that correctly uses a simile.</p>
<p>Circle the singular possessive pronoun.</p> <p>Sometimes, I eat my lunch on the patio.</p>	<p>Circle the plural possessive pronoun.</p> <p>There will be times when James and Jill will bring their lunch to school.</p>
<p>Add comma(s) where needed, if needed.</p> <p>We brought home the dog a beagle that we adopted.</p>	<p>Add comma(s) where needed, if needed.</p> <p>Pumpkins a type of a squash are fun to carve.</p>
<p>Rewrite this sentence, and correct the spelling error.</p> <p>The boys over their are playing for our team.</p>	<p>Rewrite this sentence, and correct the spelling error.</p> <p>We will have a party just in time for there birthday.</p>
<p>Turn your simple sentence into a complex sentence.</p>	<p>Is this a simple, compound, or complex sentence?</p> <p>While you were at the store, I cooked dinner.</p>
<p>Write the meaning of the root amo.</p>	<p>Write a sentence using a word with the root amo.</p>

Monday	Tuesday	Wednesday	Thursday
<p>Label the Parts of Speech of the underlined words.</p> <p><i>N = Noun, V = Verb, PN= Pronoun, Adj = Adjective, Adv = Adverb, P = Preposition, Conj=Conjunction</i></p> <p>My <u>friends</u> <u>and</u> I like riding the carousel at the <u>fair</u>.</p> <p>N, Conj, N</p>	<p>Label the Parts of Speech of the underlined words.</p> <p>We eat <u>cold</u> ice cream <u>on</u> a hot day.</p> <p>PN, Adj, P</p>	<p>Circle the subject, and underline the verb.</p> <p>My friends and I <u>like</u> riding the carousel at the fair.</p>	<p>Circle the subject, and underline the verb.</p> <p>We <u>eat</u> cold ice cream on a hot day.</p>
<p>Which figurative language device means a comparison that uses the words like, as, or than?</p> <p>Simile</p>	<p>Circle the simile in this sentence.</p> <p>The other team's quarterback is as big as a redwood tree.</p>	<p>Explain the meaning of yesterday's figurative language.</p> <p>The football player is especially large.</p>	<p>Write a sentence that correctly uses a simile.</p> <p>Answers will vary.</p>
<p>Circle the pronoun. Underline its antecedent.</p> <p><u>Jax</u> will pay for his lunch with cash today.</p>	<p>Cross out and correct the ambiguous pronoun.</p> <p>They told me I could ride the bus home with my friend.</p> <p>Answers will vary.</p>	<p>Circle the singular possessive pronoun.</p> <p>Sometimes, I eat my lunch on the patio.</p>	<p>Circle the plural possessive pronoun.</p> <p>There will be times when James and Jill will bring their lunch to school.</p>
<p>Add comma(s) where needed, if needed.</p> <p>The florist's eldest daughter, Lilly, smelled the rose.</p>	<p>Add comma(s) where needed, if needed.</p> <p>My birthday, October 31, 2005, is on Halloween.</p>	<p>Add comma(s) where needed, if needed.</p> <p>We brought home the dog, a beagle, that we adopted.</p>	<p>Add comma(s) where needed, if needed.</p> <p>Pumpkins, a type of a squash, are fun to carve.</p>
<p>Which word in this sentence is misspelled?</p> <p>The boys over their are playing for our team.</p>	<p>Which word in this sentence is misspelled?</p> <p>We will have a party just in time for there birthday.</p>	<p>Rewrite this sentence, and correct the spelling error.</p> <p>The boys over there are playing for our team.</p>	<p>Rewrite this sentence, and correct the spelling error.</p> <p>We will have a party just in time for their birthday.</p>
<p>Write a simple sentence.</p> <p>Answers will vary.</p>	<p>Turn your simple sentence into a compound sentence.</p> <p>Answers will vary.</p>	<p>Turn your simple sentence into a complex sentence.</p> <p>Answers will vary.</p>	<p>Is this a simple, compound, or complex sentence?</p> <p>While you were at the store, I cooked dinner.</p>
<p>Write the meaning of the root bell.</p> <p>War</p>	<p>Write a sentence using a word with the root bell.</p> <p>Answers will vary.</p>	<p>Write the meaning of the root amo.</p> <p>Love</p>	<p>Write a sentence using a word with the root amo.</p> <p>Answers will vary.</p>

Adding Integers

- Negative + Negative:

Add the absolute values of the two numbers and make the answer negative.

ex: $-5 + (-9)$
 $5 + 9 = 14 \rightarrow \boxed{-14}$

- Negative + Positive (or Positive + Negative):

Subtract the absolute values of the two numbers (larger minus smaller) and take the sign of the number with the greater absolute value.

ex: $-7 + 12$
 $12 - 7 = 5$
 $12 > 7$, so answer is positive
 $\rightarrow \boxed{5}$

Subtracting Integers

1. Keep the first number the same
2. Change the subtraction sign to an addition sign
3. Change the sign of the second number
4. Use integer addition rules to solve the new addition problem

ex: $-3 - 9$
 $-3 + (-9) = \boxed{-12}$

ex: $-7 - (-4)$
 $-7 + 4 = \boxed{-3}$

Multiplying & Dividing Integers

1. Ignore the signs and multiply or divide as usual
2. Determine the sign of the answer using the following rules:
 - positive \times or \div positive \rightarrow positive
 - negative \times or \div negative \rightarrow positive
 - negative \times or \div positive \rightarrow negative
 - positive \times or \div negative \rightarrow negative

ex: $-3 \cdot (-5)$
 $3 \cdot 5 = 15$
negative \cdot negative \rightarrow positive $\rightarrow \boxed{15}$

ex: $48 \div (-6)$
 $48 \div 6 = 8$
positive \div negative \rightarrow negative $\rightarrow \boxed{-8}$

Find the sum or difference.

1. $-80 + 77$	2. $77 + 160$	3. $-64 + (-33)$	4. $104 - (-92)$
5. $-105 - (-122)$	6. $185 - (-154)$	7. $-53 - (-59)$	8. $-6 + (-35)$
9. $15 - (-26) - (-39)$	10. $-93 + 191 + (-179)$	11. $18 + (-34) + 52$	12. $-50 - (-93) + (-17)$

Find the product or quotient.

13. $-60 \div 12$	14. $-194 \div (-2)$	15. $88 \cdot (-2)$	16. $-12 \cdot 10$
17. $-10 \cdot (-11)$	18. $90 \div (-6)$	19. $3 \cdot (-59)$	20. $-7 \cdot (-2)$
21. $-28 \cdot (-6) \div (-24)$	22. $-56 \cdot 14 \div (-8)$	23. $108 \div (-12) \cdot (-12)$	24. $-4 \cdot (-17) \div 2$

Adding & Subtracting Rational Numbers

Determine whether you should add or subtract using integer rules. Then add or subtract.

Decimals:

- Line up the decimal points
- Add or subtract and bring the decimal point down
- Use integer rules to determine the sign of the answer

ex: $-9.8 + 6.24$

neg + pos: subtract

$$\begin{array}{r} 9.80 \\ - 6.24 \\ \hline 3.56 \end{array} \rightarrow \boxed{-3.56}$$

ex: $5\frac{3}{4} - (-3\frac{7}{8})$

$\rightarrow 5\frac{3}{4} + 3\frac{7}{8}$

pos + pos: add

$$\begin{array}{r} 5\frac{3}{4} = \frac{6}{8} \\ + 3\frac{7}{8} = \frac{7}{8} \\ \hline 8\frac{13}{8} \end{array} \rightarrow \boxed{9\frac{5}{8}}$$

Fractions/Mixed Numbers:

- Find a common denominator and then add or subtract
- Borrow or convert an improper fraction answer, if necessary
- Use integer rules to determine the sign of the answer

Multiplying & Dividing Rational Numbers

Determine the sign of the answer using integer rules. Then multiply or divide.

Multiplying Decimals:

- Ignore the decimal points. Multiply the numbers.
- Count the decimal places in the problem to determine the location of the decimal point in the answer.

ex: $-9.23 \cdot (-1.1)$

neg · neg = pos

$$\begin{array}{r} 9.23 \leftarrow 2 \text{ dec places} \\ \times 1.1 \leftarrow 1 \text{ dec place} \\ \hline 923 \\ 9230 \\ \hline 10153 \end{array} \begin{array}{l} \downarrow \\ 3 \text{ dec places} \\ \downarrow \end{array} \rightarrow \boxed{10.153}$$

Dividing Decimals:

- Move the decimal in the divisor to the end of the number
- Move the decimal in the dividend the same number of places and then bring it straight up in quotient

ex: $-5.2 \div 0.2$

neg ÷ pos = neg

$$02 \overline{) 52} \rightarrow \boxed{-26}$$

Multiplying Fractions:

- Convert mixed numbers to improper fractions.
- Cross-simplify if possible
- Multiply the numerators and multiply the denominators
- Simplify if necessary

ex: $-1\frac{3}{4} \cdot \frac{6}{14}$

neg · pos = neg

$$\rightarrow \frac{17}{24} \cdot \frac{6^3}{14_2} = \frac{3}{4} \rightarrow \boxed{-\frac{3}{4}}$$

Dividing Fractions:

- Convert mixed numbers to improper fractions
- Flip the second fraction to its reciprocal and multiply the two fractions
- Simplify if necessary

ex: $-\frac{1}{2} \div (-\frac{3}{8})$

neg ÷ neg = pos

$$\rightarrow \frac{1}{2} \cdot \frac{8^4}{3} = \frac{4}{3} \rightarrow \boxed{1\frac{1}{3}}$$

Find the sum, difference, product, or quotient.

25. $38.61 + 36.841$	26. $1.755 - 1.23$	27. $0.71 \cdot 9.2$	28. $13.12 \div 0.1$
29. $3.651 - (-12.63)$	30. $-3.9 + (-7.6)$	31. $-14.846 \div 2.6$	32. $6 \cdot (-16.7)$
33. $26.474 - 14.527$	34. $-2.1 + 3.78$	35. $-6.15 \div (-8.2)$	36. $-12.8 \cdot (-4.88)$

Find the sum, difference, product, or quotient. Write your answer in simplest form.

37. $15\frac{1}{2} + 15\frac{1}{4}$	38. $18\frac{11}{20} - 17\frac{1}{2}$	39. $3\frac{3}{7} \div 5\frac{1}{3}$	40. $4\frac{1}{2} \cdot 2\frac{2}{5}$
41. $3\frac{1}{3} - 5\frac{1}{9}$	42. $5 \cdot \left(-1\frac{2}{5}\right)$	43. $-7\frac{3}{5} + \left(-3\frac{5}{6}\right)$	44. $-2\frac{1}{12} \div \frac{3}{8}$
45. $9 \div \left(-4\frac{1}{2}\right)$	46. $-18 + 3\frac{4}{5}$	47. $2\frac{5}{6} \cdot \left(-2\frac{2}{3}\right)$	48. $-4\frac{7}{10} - 3\frac{2}{5}$

Name:

Rising 7th Grade Summer Math Packet

About this packet!

- Summer is often a time where we lose valuable math skills. In order to prevent losing the knowledge we have learned this year, here is a little bit of work to complete over the summer.
- The work is labeled by week, to keep us doing a little bit of work throughout the summer.
- Summer is 10 weeks long, and this packet has 8 weeks worth of work.

Week 1 → Unit 1 Refresh → AREA AND SURFACE AREA

<u>Helpful to remember!</u>	<u>Formula for area:</u> $A = b \times h$ <u>Formula for surface area:</u> SUM OF ALL AREAS
<u>Helpful Vocabulary →</u> <ul style="list-style-type: none">→ Area<ul style="list-style-type: none">◆ The number of square units that covers a 2-D region, without any gaps or overlaps→ Compose<ul style="list-style-type: none">◆ “Put together”→ Decompose<ul style="list-style-type: none">◆ “Take apart”→ Parallelogram<ul style="list-style-type: none">◆ A type of quadrilateral that has two pairs of parallel sides→ Base<ul style="list-style-type: none">◆ We can choose any side length of a shape to be the base, however usually visually on the “bottom”	<ul style="list-style-type: none">→ Height<ul style="list-style-type: none">◆ The shortest distance from the base of a shape to the opposite side→ Net<ul style="list-style-type: none">◆ A 2-D figure that can be folded to make a 3-D shape→ Prism<ul style="list-style-type: none">◆ A 3-D shape that has two identical bases◆ The bases are connected by rectangles or parallelograms→ Pyramid<ul style="list-style-type: none">◆ A 3-D shape that has 1 base◆ The bases are connected by triangles→ Face<ul style="list-style-type: none">◆ A flat side of a 3-D shape

(1) Draw **three** different quadrilaterals, each with an area of 12 square units.

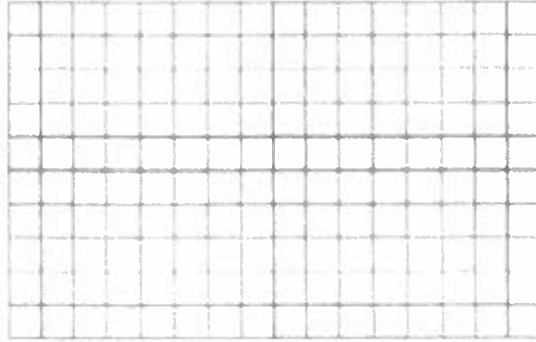

(2) The area of this shape is 24 square units. Which of these statements is true about the area?
Select **ALL** that apply.

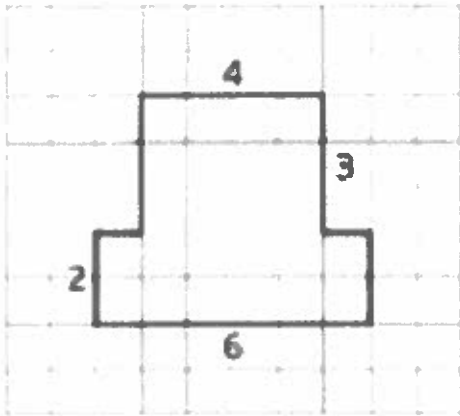

(a) The area can be found by counting the number of squares that touch the edge of the shape.

(b) It takes 24 grid squares to cover the shape without gaps and overlaps

(c) The area can be found by multiplying the side lengths that are 6 units and 4 units.

(d) The area can be found by counting the grid squares inside the shape.

(e) The area can be found by adding 4×3 and 6×2 .

(3) Here are two copies of the same figure. Show **TWO** different ways for finding the area of the shaded region.

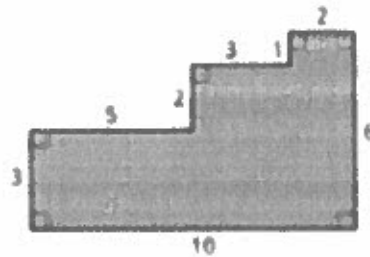
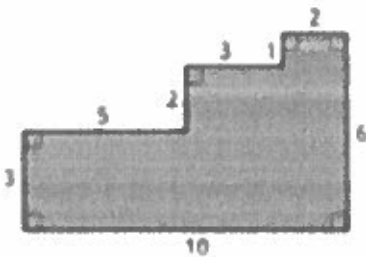

(4) Each grid square is 1 square unit. Find the area, in square units, of **each** shaded region without counting every square. Be prepared to explain your reasoning.

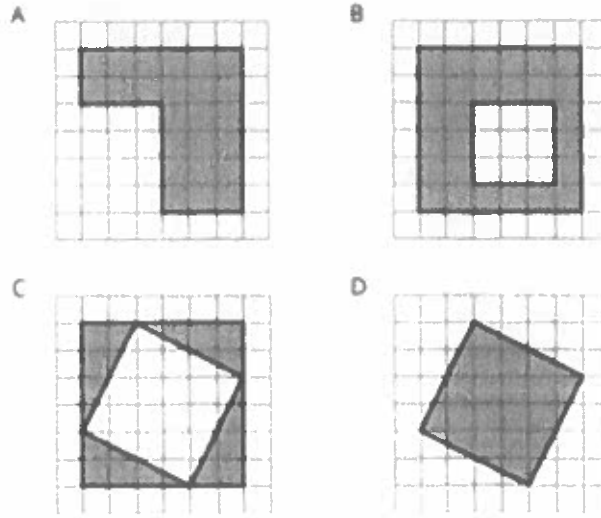

(5) Find the area of the shaded region(s) of each figure. Explain or show your work.

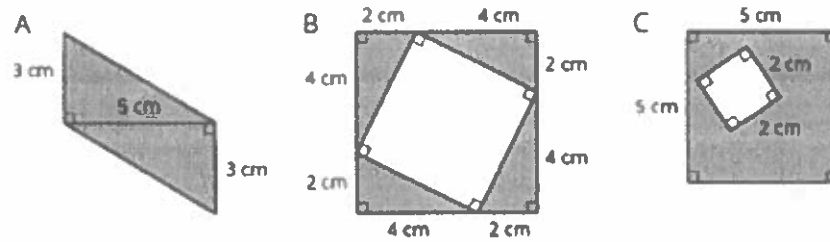

(6) Find the area of the parallelogram below. Describe/show your work.

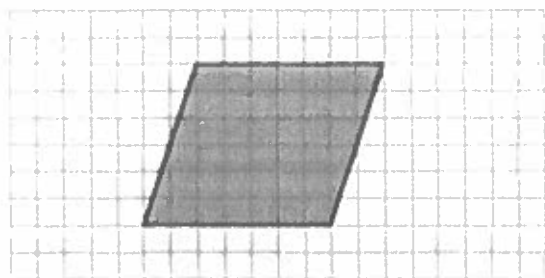

(7) What 3-D figure can be assembled from the net? **THEN**, find the surface area of the figure.

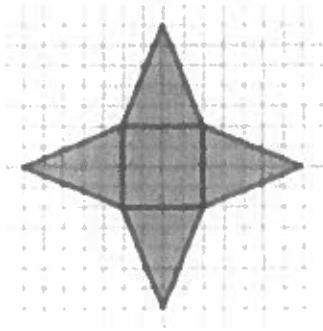

(8) Draw a net for the rectangular prism below. **THEN**, find the surface area.

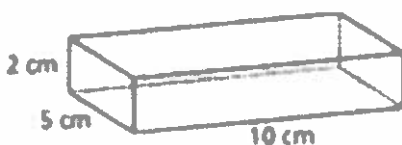

Week 2 → Unit 2 Refresh → INTRODUCING RATIOS

<p><u>Helpful to remember!</u></p>	<ul style="list-style-type: none"> - Three ways to write a ratio <ul style="list-style-type: none"> - Colon form → 2:3 - Word form → 2 to 3 - Fraction form → $\frac{2}{3}$
<p><u>Helpful Vocabulary</u> →</p> <ul style="list-style-type: none"> → Ratio <ul style="list-style-type: none"> ◆ A comparison between two or more quantities → Equivalent ratio <ul style="list-style-type: none"> ◆ RATios are equivalent if you can multiply each of the numbers in the first ratio and get the numbers in the second ratio ◆ Ratios are equivalent if they can be simplified to be the same ratio 	<ul style="list-style-type: none"> → Double number line diagram <ul style="list-style-type: none"> ◆ Uses a pair of parallel number lines to represent equivalent ratios. The locations of the tick marks on the lines match up → Per <ul style="list-style-type: none"> ◆ “For each” → Unit Price <ul style="list-style-type: none"> ◆ “How much for one” → Tape Diagram <ul style="list-style-type: none"> ◆ A group of rectangles put together to represent a relationship between quantities.

(1) Complete the sentences to describe this picture.



(a) The ratio of dogs to cats is _____.

(b) For every _____ dogs, there are _____ cats.

(2) To make a snack mix, combine 2 cups of raisins with 4 cups of pretzels and 6 cups of almonds.

(a) Create a diagram to represent the quantities of each ingredient in this recipe.

(b) Use your diagram to complete each sentence.

(i) The ratio of _____ to _____ to _____ is _____ : _____ : _____.

(ii) There are _____ cups of pretzels for every cup of raisins.

(iii) There are _____ cups of almond for every cup of raisins.

(3) At the kennel, there are 6 dogs for every 5 cats.

(a) The ratio of dogs to cats is _____ to _____.

(b) The ratio of cats to dogs is _____ to _____.

(c) For every _____ dogs there are _____ cats.

(d) The ratio of cats to dogs is _____ : _____.

(4) To make 1 batch of sky blue paint, Cami mixes 2 cups of blue paint with 1 gallon of white paint.

(a) Explain how Cami can make 2 batches of sky blue paint.

(b) Explain how to make a mixture that is a darker blue.

(c) Explain how to make a mixture that is a lighter blue.

(5) Each of these is a pair of equivalent ratios. Explain how you know they are equivalent.

(a) 4:5 and 8:10

(b) 18:3 and 6:1

(c) 2:7 and 10,000:35,000

(6) A particular shade of orange paint has 2 cups of yellow paint for every 3 cups of red paint. On the double number line, **circle** the numbers of cups of yellow and red paint needed for 3 batches of orange paint.

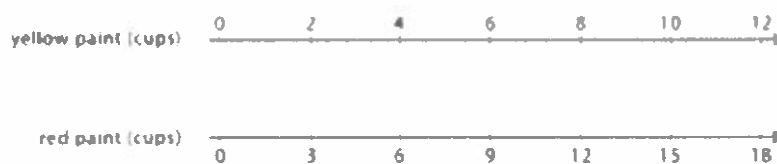

(7) 4 movie tickets cost \$48. At this rate, what is the cost of:

(a) 5 movie tickets?

(b) 11 movie tickets?

(8) Amar ran 10 meters in 2.7. Bailey ran 10 meters in 2.4 seconds.

(a) Who ran faster? Explain how you know.

(b) At this rate, how long would it take **each person** to run 50 meters. Show your work.

Name:

Monday	Tuesday
<p>Use these words from Monday's list to answer this week's questions.</p> <p>enamored amiable bellicose antebellum rebellion amateur</p>	<p>Which word from Monday's list from Monday's list means to be in love with?</p>
<p>Circle the subject, and underline the verb.</p> <p>Rhett and Carlie will sing in the talent show this week.</p>	<p>What tense is the verb in this sentence?</p> <p>Rhett and Carlie <u>will sing</u> in the talent show this week.</p>
<p>Choose the word whose meanings fit <u>both</u> sentences.</p> <p>I asked him not to _____ the glass. It looks like there is only one _____ left.</p> <p>A. drink B. drop C. cup D. break</p>	<p>Choose the word whose meanings fit <u>both</u> sentences.</p> <p>I wish you wouldn't _____ your voice. How much money did we _____ for our new club?</p> <p>A. lower B. raise C. spend D. collect</p>
<p>Circle the correct pronoun. Underline its antecedent.</p> <p>Rafaela will practice the solo on (her/she) new guitar.</p>	<p>Fill in the blank with the correct pronoun.</p> <p>Clark will read the required chapters tonight before _____ plays video games.</p>
<p>Circle the pronunciation of the word censor.</p> <div style="border: 1px solid black; padding: 5px; margin: 10px 0;"> <p>Censor [ˈsɛnsər] NOUN 1. An official who examines material that is about to be released and suppresses any parts that are considered obscene, politically unacceptable, or a threat to security. VERB 2. Examine (a book, movie, etc.) officially and suppress unacceptable parts of it.</p> </div>	<p>Which meaning of censor fits this sentence?</p> <p>Would you believe the novel <i>Charlotte's Web</i> was censored because its main characters were talking animals?</p>
<p>Circle the words with a similar denotation as music.</p> <p>band noise tunes concert</p>	<p>Which word from Monday has a positive connotation?</p>
<p>Write the meaning of the root aqua.</p>	<p>Write a sentence using a word with the root aqua.</p>

Name:

Wednesday	Thursday
<p>Which word from Monday's list means a rising up against?</p>	<p>Which word from Monday's list means one who loves to do something?</p>
<p>Choose the correct verb.</p> <p>The homecoming parade on Friday (is, are) going to have fifteen floats.</p>	<p>Choose the correct verb.</p> <p>Milly and Molly (dance, dances) in the talent show at the fair.</p>
<p>What object is given human qualities in this sentence?</p> <p>I could hear the wind whistling through the trees.</p>	<p>What is the meaning of yesterday's example of personification?</p>
<p>Identify the ambiguous pronoun.</p> <p>At school, they told the football players there would be an extra practice this week.</p>	<p>Correct the ambiguous pronoun in yesterday's sentence.</p>
<p>What part of speech is the word censor in yesterday's sentence?</p>	<p>Write a sentence using the second meaning of the word censor.</p>
<p>Which word from Monday has a negative connotation?</p>	<p>Which word from Monday best completes this sentence?</p> <p>Will you please turn your stereo off? I can't concentrate with all that _____.</p>
<p>Write the meaning of the root dia.</p>	<p>Write a sentence using a word with the root dia.</p>

Monday	Tuesday	Wednesday	Thursday
<p>Use these words to answer this week's questions.</p> <p>enamored amiable bellicose antebellum rebellion amateur</p>	<p>Which word means to be in love with?</p> <p>enamored</p>	<p>Which word means a rising up against?</p> <p>rebellion</p>	<p>Which word means one who loves to do something?</p> <p>amateur</p>
<p>Circle the subject, and underline the verb.</p> <p>Rhett and Carlie <u>will sing</u> in the talent show this week.</p>	<p>What tense is the verb in this sentence?</p> <p>Rhett and Carlie <u>will sing</u> in the talent show this week. Future</p>	<p>Choose the correct verb.</p> <p>The homecoming parade on Friday (is, are) going to have fifteen floats.</p>	<p>Choose the correct verb.</p> <p>Milly and Molly (dance, dances) in the talent show at the fair.</p>
<p>Choose the word whose meanings fit <u>both</u> sentences.</p> <p>I asked him not to _____ the glass. It looks like there is only one _____ left.</p> <p>A. drink B. drop C. cup D. break</p>	<p>Choose the word whose meanings fit <u>both</u> sentences.</p> <p>I wish you wouldn't _____ your voice. How much money did we _____ for our new club?</p> <p>A. lower B. raise C. spend D. collect</p>	<p>What object is given human qualities in this sentence?</p> <p>I could hear the wind whistling through the trees.</p>	<p>What is the meaning of yesterday's example of personification?</p> <p>It means the leaves are moving and making a noise.</p>
<p>Circle the correct pronoun. Underline its antecedent.</p> <p><u>Rafaela</u> will practice the solo on (her/she) new guitar.</p>	<p>Fill in the blank with the correct pronoun.</p> <p>Clark will read the required chapters tonight before he plays video games.</p>	<p>Identify the ambiguous pronoun.</p> <p>At school, they told the football players there would be an extra practice this week.</p>	<p>Correct the ambiguous pronoun in yesterday's sentence.</p> <p>At school, the coaches told the football players there would be an extra practice this week.</p>
<p>Circle the pronunciation of the word censor.</p> <div style="border: 1px solid black; padding: 5px;"> <p>Censor ['sensər] NOUN 1. An official who examines material that is about to be released and suppresses any parts that are considered obscene, politically unacceptable, or a threat to security. VERB 2. Examine (a book, movie, etc.) officially and suppress unacceptable parts of it.</p> </div>	<p>Which meaning of censor fits this sentence?</p> <p>Would you believe the novel <i>Charlotte's Web</i> was censored because its main characters were talking animals?</p> <p>#2</p>	<p>What part of speech is the word censor in yesterday's sentence?</p> <p>Verb</p>	<p>Write a sentence using the second meaning of the word censor.</p> <p>Answers will vary.</p>
<p>Circle the words with a similar denotation as music.</p> <p>band noise tunes concert</p>	<p>Which word has a positive connotation?</p> <p>tunes</p>	<p>Which word has a negative connotation?</p> <p>noise</p>	<p>Which word best completes this sentence?</p> <p>Will you please turn your stereo off? I can't concentrate with all that _____ noise</p>
<p>Write the meaning of the root aqua.</p> <p>Water</p>	<p>Write a sentence using a word with the root aqua.</p> <p>Answers will vary.</p>	<p>Write the meaning of the root dia.</p> <p>through; across</p>	<p>Write a sentence using a word with the root dia.</p> <p>Answers will vary.</p>

Order of Operations

Evaluate numerical expressions that contain multiple operations in the following order:

1. Grouping Symbols (complete operations in parentheses, brackets, etc.)
2. Exponents
3. Multiplication & Division (left to right)
4. Addition & Subtraction (left to right)

ex: $-2(-5 + 9)^2 - (-8) + 9$

$$-2(4)^2 - (-8) + 9$$

$$-2(16) - (-8) + 9$$

$$-32 - (-8) + 9$$

$$-24 + 9$$

$$\rightarrow \boxed{-15}$$

Evaluating Algebraic Expressions

1. Substitute the given values for the variables in the expression
2. Evaluate the expression using the order of operations

ex: evaluate

$$a - bc + b^2$$

for $a = -7$, $b = 5$, $c = -1.5$

$$-7 - (5)(-1.5) + 5^2$$

$$-7 - (5)(-1.5) + 25$$

$$-7 - (-7.5) + 25$$

$$0.5 + 25$$

$$\rightarrow \boxed{25.5}$$

Evaluate the numerical expression. Be sure to use the order of operations!

49. $78 + (-2) \cdot (-56)$	50. $-65 + \frac{6}{-3} + 40$	51. $-94 - [2 - 3(24 - 12)]$	52. $43 + (-23) - (-57)$
53. $-15 - (-11) + 5 \cdot (-4)^3$	54. $-26 - (-64) + (-3)^4$	55. $-84 \div 4 + (-20)$	56. $-56 + (-50) + (-7) \cdot (-9)$
57. $-7.6 - 3 + 2.1 \cdot (-8)$	58. $-\frac{2}{3} + \frac{5}{6} \div \frac{1}{2}$	59. $-8 + 3(-2.7 + 4.23)$	60. $-3\frac{1}{2} \cdot \left(-2\frac{3}{4}\right) + \left(-4\frac{1}{4}\right)$

Evaluate the algebraic expression for $a = -12$, $b = 6$, $c = -4$, and $d = 3$.

61. $a - b + c$	62. $b - cd$	63. $b(cd - a)$
64. $\frac{b}{c} - d$	65. $bd + ac$	66. $\frac{a}{d} + c^2$

One-Step Equations

- Addition Equations:

Subtract the number being added to the variable from both sides of the equation

$$\begin{array}{r} \text{ex: } y + 23 = -9 \\ \quad \quad \quad -23 \quad -23 \\ \hline \boxed{y = -32} \end{array}$$

- Subtraction Equations:

Add the number being subtracted from the variable to both sides of the equation

$$\begin{array}{r} \text{ex: } w - 13 = -5 \\ \quad \quad \quad +13 \quad +13 \\ \hline \boxed{w = 8} \end{array}$$

- Multiplication Equations:

Divide both sides of the equation by the number next to the variable

$$\begin{array}{r} \text{ex: } 6x = -18 \\ \quad \quad \quad \div 6 \quad \div 6 \\ \hline \boxed{x = -3} \end{array}$$

- Division Equations:

Multiply both sides of the equation by the number under the variable

$$\begin{array}{r} \text{ex: } \frac{h}{3} = 4 \\ \quad \quad \quad \cdot 3 \quad \cdot 3 \\ \hline \boxed{h = 12} \end{array}$$

Two-Step Equations

- Undo operations one at a time with inverse operations, using the order of operations in reverse (i.e. undo addition/subtraction before multiplication/division)

$$\begin{array}{r} \text{ex: } 7x - 4 = -32 \\ \quad \quad \quad +4 \quad +4 \\ \hline 7x = -28 \\ \quad \quad \quad \div 7 \quad \div 7 \\ \hline \boxed{x = -4} \end{array}$$

- Be sure to always do the same thing to both sides of the equation!

$$\begin{array}{r} \text{ex: } \frac{j}{5} + 3 = 15 \\ \quad \quad \quad -3 \quad -3 \\ \hline \frac{j}{5} = 2 \\ \quad \quad \quad \cdot 5 \quad \cdot 5 \\ \hline \boxed{j = 10} \end{array}$$

$$\begin{array}{r} \text{ex: } \frac{b+7}{3} = -2 \\ \quad \quad \quad \cdot 3 \quad \cdot 3 \\ \hline b+7 = -6 \\ \quad \quad \quad -7 \quad -7 \\ \hline \boxed{b = -13} \end{array}$$

Solve the one-step equation.

67. $19 + j = -34$	68. $m - 26 = 13$	69. $\frac{x}{5} = -3$	70. $12f = 216$
71. $g - (-31) = -7$	72. $\frac{h}{9} = 13$	73. $b + (-3) = -9$	74. $-4w = -280$

Solve the two-step equation.

75. $5m - 3 = 27$	76. $7 + \frac{y}{2} = -3$	77. $4 + 3r = -8$	78. $\frac{1}{2}p - 4 = 7$
79. $\frac{k+8}{3} = -2$	80. $\frac{f}{5} - (-13) = 12$	81. $-15 - \frac{g}{3} = -5$	82. $-8 + 4m = 2$
83. $-18 - \frac{3}{4}v = 3$	84. $\frac{-5+n}{4} = -1$	85. $3.5m + 0.75 = -6.25$	86. $2y + 3 = 19$

Week 3 → Unit 3 Refresh → UNIT RATES AND PERCENTAGES

Helpful to remember!	- Percent is ALWAYS out of 100%
Helpful Vocabulary → <ul style="list-style-type: none">→ Unit Rate<ul style="list-style-type: none">◆ A rate “per 1”→ Unit Price<ul style="list-style-type: none">◆ The price “per 1”→ Pace<ul style="list-style-type: none">◆ One way to describe how fast something is moving◆ Tells how much time it takes the object to travel a certain amount of distance	<ul style="list-style-type: none">→ Speed<ul style="list-style-type: none">◆ One way to describe how fast something is moving◆ Tells how much distance something can travel in a certain amount of time→ Percentage<ul style="list-style-type: none">◆ Rate “per 100”

(1) Mei and Keira were on scooters. Mei traveled 15 meters per 6 seconds. Keira travels 22 meters in 10 seconds. Who was moving faster? Show your work.

(2) Here are the prices for cans of juice that are the same brand and the same size at different stores. Which store offers the best deal? Show your work.

Store X: 4 cans for \$2.48

Store Y: 5 cans for \$3.00

Store X: \$0.59 per can

(3) **Two pounds of grapes cost \$6.** Complete the table using this information.

grapes (pounds)	price (dollars)
2	6
	1
1	

(4) A farm lets you pick 3 pints of raspberries for \$12.00.

(a) What is the cost per pint?

(b) How many pints do you get per dollar?

(c) At this rate, how many pints can you afford for \$20?

(d) At this rate, how much will 8 pints of raspberries cost?

(5) Complete the table so that the cost per banana remains the same (\$0.50).

number of bananas	cost in dollars	unit price (dollars per banana)
4		0.50
6		0.50
7		0.50
10		0.50
	10.00	0.50
	16.50	0.50

(6) Fill in the blank: The value of 8 dimes is _____% of the value of a dollar.

(7) Name a combination of coins that is 130% of the value of a dollar.

(8) What percentage of a dollar is the value of **each** coin combination?

(a) 4 dimes

(b) 1 nickel and 3 pennies

(c) 5 quarters and 1 dime

(9) A large bottle of juice contains 500 milliliters of juice. A medium bottle contains **70% as much**. Use the double number line to determine how many milliliters are in the **medium** bottle.



(10) A 16-oz ounce bottle of orange juice contains 200 milligrams of vitamin C, which is **250%** of the daily recommended value. What is **100%** of the daily recommended value?

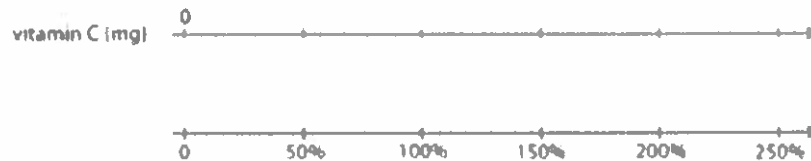

(11) A sign in front of a roller coaster says, "You must be 40 inches tall to ride." What percentage of this height is:

(a) 34 inches

(b) 54 inches

Name:

Monday	Tuesday
<p>Use these words to answer this week's questions.</p> <p>aquamarine aquarium aquatic diameter diagram diaphragm</p>	<p>Which word from Monday's list means the length of a line going through a circle?</p>
<p>What does the metaphor in this sentence mean?</p> <p>My friend Joey is a clown.</p>	<p>What does the metaphor in this sentence mean?</p> <p>Mom said my bedroom is a pig sty.</p>
<p>Choose the word whose meanings fit <u>both</u> sentences.</p> <p>We can use this _____ to measure that table. A new _____ was elected by the people to govern their country.</p> <p>A. yardstick B. king C. ruler D. president</p>	<p>Choose the word whose meanings fit <u>both</u> sentences.</p> <p>A statement should be followed by a _____.</p> <p>The class _____ seemed to pass slowly.</p> <p>A. question mark B. decade C. period D. time</p>
<p>Which word in this sentence is misspelled?</p> <p>Its about time to rake the leaves in the yard.</p>	<p>Rewrite yesterday's sentence, and correct the spelling error.</p>
<p>Format the title correctly.</p> <p>We will read the article Robots to Perform Surgery in this week's newspaper.</p>	<p>Format the title correctly.</p> <p>The documentary called The Amazing World of Robots will air tomorrow night.</p>
<p>Rewrite this description in the possessive form.</p> <p>the phone that belongs to Anita</p>	<p>Rewrite this description in the possessive form.</p> <p>the tools that belong to my dad</p>
<p>Underline the prepositional phrase, and circle the word it modifies.</p> <p>My favorite place to walk is the park across the street.</p>	<p>Does the prepositional phrase in yesterday's sentence function as an adjective or adverb?</p>

Name:

Wednesday	Thursday
<p>Which word from Monday's list means a glass-sided tank, bowl, or the like, in which fish or other living aquatic animals or plants are kept?</p>	<p>Which word from Monday's list means a drawing or plan that outlines and explains the parts of something?</p>
<p>Complete this simile.</p> <p>As big as _____</p>	<p>Complete this simile.</p> <p>As happy as _____</p>
<p>Circle the words that would be synonyms for the word curious with a positive connotation.</p> <p>interested nosy snooping inquiring</p>	<p>Circle the words that would be synonyms for the word curious with a negative connotation.</p> <p>interested nosy snooping inquiring</p>
<p>Which word in this sentence is misspelled?</p> <p>Mary's dog is going to get it's shots this weekend at the clinic.</p>	<p>Rewrite yesterday's sentence, and correct the spelling error.</p>
<p>Correct the comma error in this sentence.</p> <p>Robots, can help doctors perform surgeries more accurately.</p>	<p>Correct the comma error in this sentence.</p> <p>A doctor will use a robot, and her own skills to perform the heart surgery.</p>
<p>Circle the correct verb.</p> <p>The frames on the shelf (was, were) bought at the thrift store.</p>	<p>What tense is the verb in yesterday's sentence?</p>
<p>Underline the prepositional phrase, and circle the word it modifies.</p> <p>A surgical robot must be directed by a human.</p>	<p>Does the prepositional phrase in yesterday's sentence function as an adjective or adverb?</p>

Monday	Tuesday	Wednesday	Thursday
<p>Use these words to answer this week's questions.</p> <p>aquamarine aquarium aquatic diameter diagram diaphragm</p>	<p>Which word means the length of a line going through a circle?</p> <p>diameter</p>	<p>Which word means a glass-sided tank, bowl, or the like, in which fish or other living aquatic animals or plants are kept?</p> <p>aquarium</p>	<p>Which word means a drawing or plan that outlines and explains the parts of something?</p> <p>diagram</p>
<p>What does the metaphor in this sentence mean?</p> <p>My friend Joey is a clown.</p> <p>It means Joey likes to make jokes and have fun.</p>	<p>What does the metaphor in this sentence mean?</p> <p>Mom said my bedroom is a pig sty.</p> <p>The bedroom is very messy.</p>	<p>Complete this simile.</p> <p>As big as _____</p> <p>Answers will vary.</p>	<p>Complete this simile.</p> <p>As happy as _____</p> <p>Answers will vary.</p>
<p>Choose the word whose meanings fit <u>both</u> sentences.</p> <p>We can use this _____ to measure that table. A new _____ was elected by the people to govern their country.</p> <p>A. yardstick B. king C. ruler D. president</p>	<p>Choose the word whose meanings fit <u>both</u> sentences.</p> <p>A statement should be followed by a _____. The class _____ seemed to pass slowly.</p> <p>A. question mark B. decade C. period D. time</p>	<p>Circle the words that would be synonyms for the word curious with a positive connotation.</p> <p>interested nosy snooping inquiring</p>	<p>Circle the words that would be synonyms for the word curious with a negative connotation.</p> <p>interested nosy snooping Inquiring</p>
<p>Which word in this sentence is misspelled?</p> <p>Its about time to rake the leaves in the yard.</p>	<p>Rewrite yesterday's sentence, and correct the spelling error.</p> <p>It's about time to rake the leaves in the yard.</p>	<p>Which word in this sentence is misspelled?</p> <p>Mary's dog is going to get it's shots this weekend at the clinic.</p>	<p>Rewrite yesterday's sentence, and correct the spelling error.</p> <p>Mary's dog is going to get its shots this weekend at the clinic.</p>
<p>Format the title correctly.</p> <p>We will read the article "Robots to Perform Surgery" in this week's newspaper.</p>	<p>Format the title correctly.</p> <p>The documentary called <u>The Amazing World of Robots</u> will air tomorrow night.</p>	<p>Correct the comma error in this sentence.</p> <p>Robots can help doctors perform surgeries more accurately.</p>	<p>Correct the comma error in this sentence.</p> <p>A doctor will use a robot and her own skills to perform the heart surgery.</p>
<p>Rewrite this description in the possessive form.</p> <p>the phone that belongs to Anita</p> <p>Anita's phone</p>	<p>Rewrite this description in the possessive form.</p> <p>the tools that belong to my dad</p> <p>Dad's tools</p>	<p>Circle the correct verb.</p> <p>The frames on the shelf (was, were) bought at the thrift store.</p>	<p>What tense is the verb in yesterday's sentence?</p> <p>Past tense</p>
<p>Underline the prepositional phrase, and circle the word it modifies.</p> <p>My favorite place to walk is <u>the park</u> across the street.</p>	<p>Does the prepositional phrase in yesterday's sentence function as an adjective or adverb?</p>	<p>Underline the prepositional phrase, and circle the word it modifies.</p> <p>A surgical robot must be <u>directed</u> by a human.</p>	<p>Does the prepositional phrase in yesterday's sentence function as an adjective or adverb?</p>

Unit Rates

- Convert a rate to a unit rate by dividing the numerator by the denominator
 - Write your answer as a fraction with labels for the both the numerator and denominator OR as one number labeled with the first unit "per" the second unit

ex: Find the unit price:

$$\frac{\$2.99}{12 \text{ eggs}}$$

$$2.99 \div 12 \approx 0.25$$

$$\rightarrow \frac{\$0.25}{1 \text{ egg}} = \$0.25 \text{ per egg}$$

Solving Proportions

- Set cross-products equal to each other
- Solve the equation for the given variable

ex: $\frac{5}{b} = \frac{4}{10}$

$$5 \cdot 10 = 4b$$

$$\frac{50}{4} = \frac{4b}{4} \rightarrow \boxed{b = 12.5}$$

Proportion Word Problems

- Set up a ratio with what you know
- Set up a second ratio using a variable for the unknown quantity
 - Be sure that the units in the numerator match the units in the denominator of the first ratio and the units in the denominator match the units in the denominator of the first ratio.
- Make a proportion by setting the two ratios equal to each other
- Solve the proportion.

ex: A recipe calls for 2 cups of sugar for 36 cookies. How many cups of sugar are needed to make 48 cookies?

$$\frac{2 \text{ cups}}{36 \text{ cookies}} = \frac{x \text{ cups}}{48 \text{ cookies}}$$

$$2 \cdot 48 = 36x$$

$$\frac{96}{36} = \frac{36x}{36}$$

$$\boxed{x = 2\frac{2}{3} \text{ cups}}$$

Convert to a unit rate.

87. $\frac{513 \text{ miles}}{9 \text{ hours}}$	88. $\frac{180 \text{ words}}{5 \text{ minutes}}$	89. $\frac{\$2.53}{8 \text{ oz}}$
---	---	-----------------------------------

Solve the proportion.

90. $\frac{h}{6} = \frac{20}{24}$	91. $\frac{5}{7} = \frac{c}{14}$	92. $\frac{6}{8} = \frac{21}{b}$	93. $\frac{30}{j} = \frac{26}{39}$
94. $\frac{5}{k} = \frac{15}{20}$	95. $\frac{32}{112} = \frac{a}{14}$	96. $\frac{16}{7} = \frac{18}{g}$	97. $\frac{w}{60} = \frac{15}{200}$

Use a proportion to solve the word problem.

98. A cookie recipe calls for 2 eggs and 3 cups of flour. You only have 1 egg, so you have to cut the recipe. How much flour should you use?	99. Jack can run 2 miles in 15 minutes. At that rate, how far would you expect him to run in an hour?	100. Sue read 15 pages of her book in 25 minutes. At that rate, how long will it take her to read the next 10 pages?	101. The ratio of cats to dogs at the park was 1:4. If there were 12 dogs, how many cats were at the park?
102. If 2 pounds of apples cost \$2.60, how much would 5 pounds of apples cost?	103. If you burn 184 calories running 2 miles, how many calories would you burn if you run 5 miles?	104. In a shipment of 300 parts, there are 12 defective parts. How many defective parts would you expect to find in a shipment of 1,000 parts?	105. The ratio of 12-year-olds to 13-year-olds in Mr. Wu's class is 5:3. If there are 24 students in the class, how many students are 13 years old?

Solving Percent Problems

Using a Proportion:

- Set up a proportion in the following format & solve

$$\frac{\%}{100} = \frac{\text{part}}{\text{whole}}$$

ex: 25 is what percent of 500?

proportion: $\frac{x}{100} = \frac{25}{500} \rightarrow 500x = 2500$
 $x = 5$

equation: $25 = 500x \rightarrow 0.05 = x$
 $\rightarrow x = \boxed{5\%}$

ex: What is 15% of 88?

proportion: $\frac{15}{100} = \frac{x}{88} \rightarrow 1320 = 100x$
 $13.2 = x$

equation: $x = 0.15(88) \rightarrow x = 13.2$
 $\rightarrow x = \boxed{13.2}$

ex: 18 is 30% of what number?

proportion: $\frac{30}{100} = \frac{18}{x} \rightarrow 30x = 1800$
 $x = 60$

equation: $18 = 0.3x \rightarrow 60 = x$
 $\rightarrow x = \boxed{60}$

Using an Equation:

- Set up an equation in the following format & then solve

$$\text{part} = \text{percent} \times \text{whole}$$

(The percent must be in decimal or fraction form in the equation!)

Percent Applications

Percent of Change

- Set up a proportion in the following format & solve

$$\frac{\%}{100} = \frac{\text{amount of change}}{\text{original amount}}$$

ex: Enrollment in 2015 was 4,850. In 2020, enrollment was 5,122. Find the percent of change.

$$\frac{x}{100} = \frac{272}{4,850}$$

$\leftarrow \begin{array}{l} \text{amt of change:} \\ 5,122 - 4,850 = 272 \end{array}$
 $\leftarrow \text{original enrollment}$

$$\rightarrow x \approx \boxed{5.6\% \text{ increase}}$$

Tax:

- Find the amount of tax using a proportion or equation. Then add the tax to the original amount to find the total cost.

ex: Find the total cost of a \$8.95 book with 7% sales tax.

$$x = 0.07 \cdot 8.95 \rightarrow x \approx 0.63$$

$$8.95 + 0.63 = \boxed{\$9.58}$$

Discount:

- Find the amount of the discount using a proportion or equation. Then subtract that amount from the original price to find the sale price.

ex: A \$18.60 shirt is on sale for 30% off. Find the sale price.

$$\frac{30}{100} = \frac{x}{18.60} \rightarrow x \approx 5.58$$

$$18.60 - 5.58 = \boxed{\$13.02}$$

Simple Interest:

- Use the equation $I = PRT$
 - I = interest, P = principal (starting amount), R = interest rate, T = time (in years)

ex: \$5,000 is kept in an account with a 1.5% interest rate for 10 years. How much simple interest is earned?

$$I = 5,000 \cdot 0.015 \cdot 10 = \boxed{\$750}$$

$\leftarrow \begin{array}{l} \text{convert rate} \\ \text{to decimal} \end{array}$

Solve the percent problem.

106. Find 15% of 85.	107. 6 is 75% of what number?	108. 40 is what percent of 320?	109. What is 20% of 45?
110. 70 is what percent of 350?	111. Find 33.3% of 81.	112. 9 is 45% of what number?	113. What percent of 60 is 12?
114. 5% of the lights on the light string are out. If there are 100 lights on the string, how many are out?	115. There were 27 students in Jerome's class last year. This year there are 30 students in his class. Find the percent of change.	116. A \$58 camera is on sale for 20% off. Find the sale price.	117. A \$60 camera is on sale for \$50. Find the percent of change.
118. Find the total price of a \$14.00 shirt including the 7% sales tax.	119. How much simple interest is earned after 10 years if \$200 is put in an account with a 1.25% interest rate?	120. Your bill at a diner comes to \$45. If you want to leave the waitress a 20% tip, how much money should you give her?	121. Find the final price of a \$58 video game that is on sale for 15% off, after the 6.5% sales tax is included.

Week 4 → Unit 4 Refresh → DIVIDING FRACTIONS

<u>Helpful to remember!</u>	- Keep Change Flip (<i>how to divide fractions</i>)
<u>Helpful Vocabulary</u> → → Numerator ◆ Top of a fraction → Denominator ◆ Bottom of a fraction	→ Quotient ◆ Answer to a division problem → Reciprocal ◆ Inverse of a fraction

(1) Order from tallest to shortest:

- Stack of pennies that is 1 ft high
- Stack of books that is 1 ft high
- Stack of dollar bills that is 1 ft high
- Stack of slices of bread that is 1 ft high

(2) 20 pounds of strawberries are being shared equally by a group of friends. The equation: $20 \div 5 = 4$ represents the situation.

(a) If the 5 represents the number of people, what does the 4 represent?

(b) If the 5 represents the pounds of strawberries per person, what does the 4 represent?

(3) A 6th grade science club needs \$180 to pay for the tickets to a science museum. All tickets cost the same amount.

What could $180 \div 15$ mean in this context? **THEN**, find the solution & explain what it represents.

(4) Which question can be represented by the equation: $? \cdot \frac{1}{8} = 3$

- (a) How many 3s are in $\frac{1}{8}$?
- (b) What is 3 groups of $\frac{1}{8}$?
- (c) How many $\frac{1}{8}$ s are in 3?
- (d) What is $\frac{1}{8}$ of 3?

(5) Use the tape diagram to represent and answer the question. How many $\frac{2}{5}$ s are in $1\frac{1}{2}$?

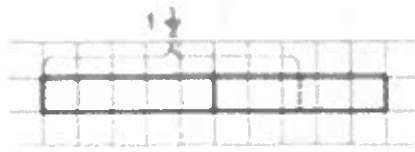

(6) A recipe calls for $\frac{1}{2}$ pounds of flour for 1 batch. How many batches can be made with each of the following amounts?

(a) 1 lb

(b) $\frac{3}{4}$ lb

(c) $\frac{1}{4}$ lb

(7) Find each quotient (aka answer).

(a) $5 \div \frac{1}{10}$

(c) $5 \div \frac{9}{10}$

(b) $5 \div \frac{3}{10}$

(8) Find each quotient (aka answer).

(a) $\frac{8}{12} \div \frac{7}{8} =$

(b) $\frac{4}{5} \div \frac{1}{4} =$

$$(c) \frac{3}{4} \div \frac{4}{5} =$$

$$(g) \frac{2}{3} \div \frac{3}{9} =$$

$$(d) \frac{1}{2} \div \frac{2}{3} =$$

$$(h) \frac{1}{2} \div \frac{5}{8} =$$

$$(e) \frac{2}{7} \div \frac{5}{9} =$$

$$(i) \frac{2}{4} \div \frac{2}{5} =$$

$$(f) \frac{1}{10} \div \frac{5}{6} =$$

$$(j) \frac{5}{7} \div \frac{3}{7} =$$

Week 5 → Unit 5 Refresh → ARITHMETIC IN BASE TEN

<u>Helpful to remember!</u>	<ul style="list-style-type: none">- For addition & subtraction<ul style="list-style-type: none">- ALWAYS line up the decimals- For multiplication & division<ul style="list-style-type: none">- Decimals don't need to be lined up, but do not forget about them!
<u>Helpful Vocabulary →</u>	<p>→ Long division</p> <ul style="list-style-type: none">◆ A way to show the steps for dividing numbers in decimal form

5-A-Day Language Review: Week 1

Monday

- 1 Rewrite the sentence without the **dangling** or **misplaced modifier**.

Hungry after being in class all morning, the cafeteria was filled with students.

- 2 Identify the type of **connotation** for the words below (-, +, •).

elegant

ostentatious

fine

- 3 Meetings between the two senators are outwardly calm and friendly. In fact, many people would describe their relationship as pleasant. Inside, however, both people are **seething** with rage. It is just a matter of time until one of them explodes.

seething means: _____

- 4 Choose the **synonym** for the following word:

dynamic

idle

changing

stagnate

complex

- 5 **impolitely** >>>> → prefix: _____ base or root: _____ suffix: _____

- 1 Simplify the sentence by **eliminating** any **wordiness** or **redundancies**.

City safety inspectors are in the process of currently reviewing the construction site and may completely close it down in about 2 to 3 days.

- 2 Circle the **misspelled word**, and write it correctly on the line below.

acomplishment baggage bureau © _____

- 3 Underline and identify the **figure of speech** below.

And it seems to me you lived your life like a candle in the wind – Elton John

Hyperbole Personification Simile Metaphor Idiom

- 4 What does the **figure of speech** from above mean?

- 5 Is the following a **phrase** or a **clause**? If it is a **clause**, indicate if it is **independent** or **dependent**.

Around the corner

Tuesday

5-A-Day Language Review: Week 1

Wednesday

- 1 Use the meanings of the **root** and **affix** to define the word. Then provide a dictionary definition.

docile



"doc" - teach

"ile" - capable of being, like

My Definition: _____

Dictionary Definition: _____

- 2 Find 5 words that contain the **root** or **affix** from above.

- 3 Which of the following might someone be **persecuted** for?

a) stealing from a store

b) belonging to a particular ethnic group

c) having different beliefs

d) driving without a license

- 4 Add **commas** where needed to the sentence below.

However he was a spoiled obstinate child.

- 5 Choose the **antonym** for the following word:

divulge

conceal

pretend

disclose

encourage

- 1 Select a word from "Monday # 2" that has the best **connotation** to complete this sentence.

Most people would just gawk in disbelief at his _____ clothes and car.

- 2 Identify if the adjectives in the text below are coordinate. If they are **coordinate adjectives**, add a comma. If they are not coordinate adjectives, label them n/c for "non-coordinate."

The kind compassionate students raised money for the animal shelter.

- 3 Circle the definition that matches the word used in the sentence below.

lofty

1. adj. Very tall or high

2. adj. Noble in feeling or high in ideals

3. adj. Showing a superior attitude

She had a lofty way of speaking that made others feel inferior.

- 4 Identify if the following sentence is **simple, compound, complex, or compound-complex**.

We went to the movies last night, and we really enjoyed it.

- 5 Choose a matching **analogy**.

ravenous : hungry

a) fascinating : interesting

b) firm : hard

c) serious : grave

d) strange : odd

Thursday

Probability

Probability of Simple Events

$$P(\text{event}) = \frac{\# \text{ of favorable outcomes}}{\# \text{ of possible outcomes}}$$

ex: You roll a number cube. Find $P(3)$.

When you roll a number cube, there are 6 possible outcomes:
(1, 2, 3, 4, 5, or 6)

There is 1 favorable outcome: (rolling a 3)

$$\rightarrow P(3) = \frac{1}{6}$$

Probability of Compound Events

- Independent Events

$$P(A \text{ and } B) = P(A) \cdot P(B)$$

- Dependent Events

$$P(A \text{ then } B) = P(A) \cdot P(B \text{ after } A)$$

ex: You roll 2 number cubes. Find $P(3, \text{ odd})$.

$$P(3) \cdot P(\text{odd}) = \frac{1}{6} \cdot \frac{3}{6} = \frac{1}{12}$$

ex: There are 3 red crayons and 4 blue crayons in a bag. You pick one out without looking, do not replace it, and then pick another. Find $P(\text{red, red})$

$P(\text{red}) \cdot P(\text{red after picking red})$:

$$\frac{3}{7} \cdot \frac{2}{6} = \frac{1}{7}$$

Angle Relationships

- Adjacent Angles: angles that share a vertex and a common side

ex:

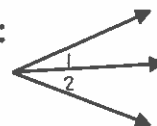

$\angle 1$ and $\angle 2$ are adjacent because they share a vertex and side.

- Complementary Angles: angles with a sum of 90°

ex:

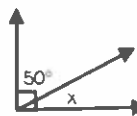

The angles are complementary because they form a right angle, so
 $50 + x = 90$
 $\rightarrow x = 40^\circ$

- Supplementary Angles: angles with a sum of 180°

ex:

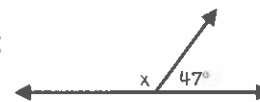

The angles are supplementary because they form a line, so
 $x + 47 = 180$
 $\rightarrow x = 133^\circ$

- Vertical Angles: a pair of opposite angles formed where two lines intersect. Vertical angles are congruent.

ex:

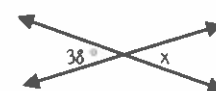

The angles are vertical because they are across from each other, so
 $x = 38^\circ$

A bag of marbles contains 8 blue marbles, 6 red marbles, and 4 green marbles. Find the probability of each event if you choose marbles without looking in the bag.

122. P(green)	123. P(red)	124. P(blue)	125. You pick a marble, <u>replace it</u> , and then pick another. Find P(blue, blue).
126. You pick a marble, <u>replace it</u> , and then pick another. Find P(red, green).	127. You pick a marble, <u>do not replace it</u> , and then pick another. Find P(blue, blue).	128. You pick a marble, <u>do not replace it</u> , and then pick another. Find P(red, green).	129. You pick a marble, <u>do not replace it</u> , and then pick another. Find P(green, green).

Identify the relationship between $\angle 1$ and $\angle 2$.

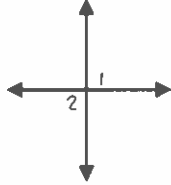
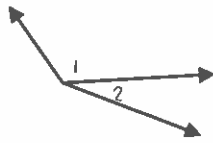
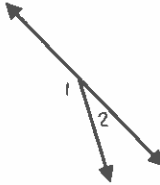
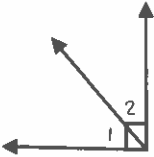
130. 	131. 	132. 	133. 
---	---	--	---

Find the value of x .

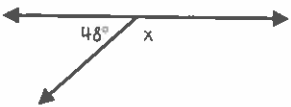
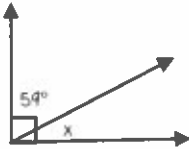
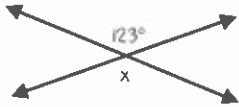
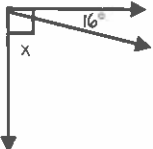
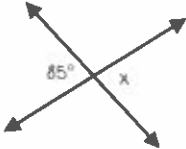
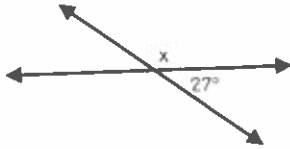
134. 	135. 	136. 
137. 	138. 	139. 

2-Dimensional Geometry Formulas

- Perimeter is the distance around a polygon
 - Perimeter of Any Figure: $P = \text{sum of side lengths}$
- Circumference is the distance around a circle
 - $C = \pi d$
- Area is the space inside a figure
 - Area of Parallelogram: $A = bh$
 - Area of Triangle: $A = \frac{1}{2}bh$
 - Area of Trapezoid: $A = \frac{1}{2}h(b_1 + b_2)$
 - Area of Circle: $A = \pi r^2$

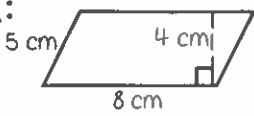
ex:  $P = 5 + 8 + 5 + 8$
 $\rightarrow P = 26 \text{ cm}$
 $A = 8 \cdot 4$
 $\rightarrow A = 32 \text{ cm}^2$

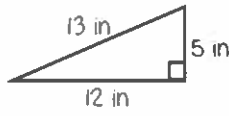
ex:  $P = 5 + 12 + 13$
 $\rightarrow P = 30 \text{ in}$
 $A = \frac{1}{2} \cdot 5 \cdot 12$
 $\rightarrow A = 30 \text{ in}^2$

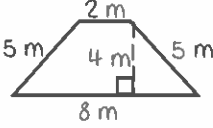
ex:  $P = 5 + 2 + 5 + 8$
 $\rightarrow P = 20 \text{ m}$
 $A = \frac{1}{2} \cdot 4 \cdot (2 + 8)$
 $\rightarrow A = 20 \text{ m}^2$

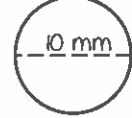
ex:  $C = 10 \cdot \pi$
 $\rightarrow C \approx 31.4 \text{ mm}$
 $A = \pi \cdot 5^2$
 $\rightarrow A \approx 78.5 \text{ mm}^2$

Abbreviations used in Formulae:

P = perimeter, C = circumference, d = diameter, b = base, h = height, r = radius

3-Dimensional Geometry Formulas

- Volume is the capacity of a 3-dimensional figure
 - Volume of Rectangular Prism: $V = lwh$
 - Volume of Cylinder: $V = \pi r^2 h$
- Surface Area is the sum of the areas of all the faces on a 3-dimensional figure
 - Surface Area of Rectangular Prism:
 $SA = 2lw + 2lh + 2wh$
 - Surface Area of Cylinder: $SA = 2\pi r^2 + 2\pi rh$

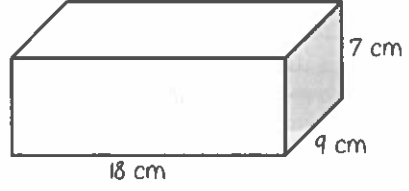
ex:  $V = 18 \cdot 9 \cdot 7$
 $\rightarrow V = 1,134 \text{ cm}^3$
 $SA = 2 \cdot 18 \cdot 9 + 2 \cdot 9 \cdot 7 + 2 \cdot 18 \cdot 7$
 $\rightarrow SA = 702 \text{ cm}^2$

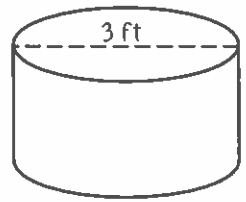
ex:  $V = \pi \cdot 1.5^2 \cdot 2$
 $\rightarrow V \approx 14.1 \text{ ft}^3$
 $SA = 2 \cdot \pi \cdot 1.5^2 + 2 \cdot \pi \cdot 1.5 \cdot 2$
 $\rightarrow SA \approx 33.0 \text{ ft}^2$

Abbreviations used in Formulae:

V = volume, SA = surface area, l = length, w = width, h = height, r = radius

Find the perimeter (or circumference) and area of the given shape. Round to the nearest tenth if necessary.

140.

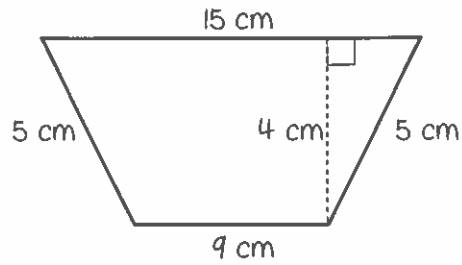

141.

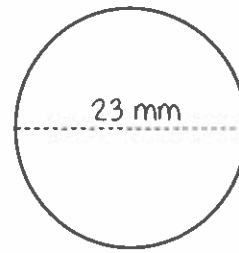

142.

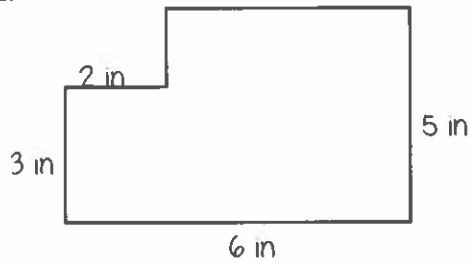

143.

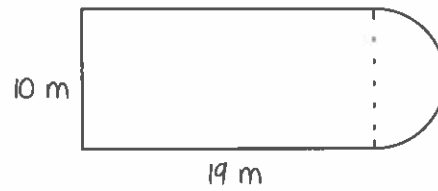

Find the surface area and volume of the given figure. Round to the nearest tenth if necessary.

144.

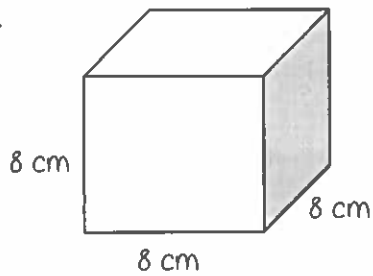

145.

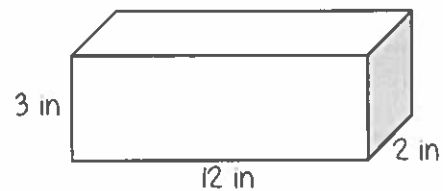

146.

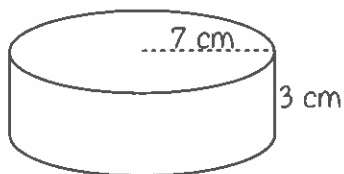

147.

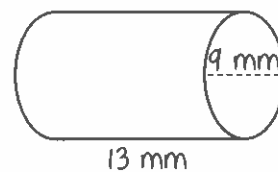

Find the sum or difference.

ANSWERS

1. $-80 + 77$ -3	2. $77 + 160$ 237	3. $-64 + (-33)$ -97	4. $104 - (-92)$ 196
5. $-105 - (-122)$ 17	6. $185 - (-154)$ 339	7. $-53 - (-59)$ 6	8. $-6 + (-35)$ -41
9. $15 - (-26) - (-39)$ 80	10. $-93 + 191 + (-179)$ -81	11. $18 + (-34) + 52$ 36	12. $-50 - (-93) + (-17)$ 26

Find the product or quotient.

13. $-60 \div 12$ -5	14. $-194 \div (-2)$ 97	15. $88 \cdot (-2)$ -176	16. $-12 \cdot 10$ -120
17. $-10 \cdot (-11)$ 110	18. $90 \div (-6)$ -15	19. $3 \cdot (-59)$ -177	20. $-7 \cdot (-2)$ 14
21. $-28 \cdot (-6) \div (-24)$ -7	22. $-56 \cdot 14 \div (-8)$ 98	23. $108 \div (-12) \cdot (-12)$ 108	24. $-4 \cdot (-17) \div 2$ 34

Find the sum, difference, product, or quotient!

25. $38.61 + 36.841$ 75.451	26. $1.755 - 1.23$ 0.525	27. $0.71 \cdot 9.2$ 6.532	28. $13.12 \div 0.1$ 131.2
29. $3.651 - (-12.63)$ 16.281	30. $-3.9 + (-7.6)$ -11.5	31. $-14.846 \div 2.6$ -5.71	32. $6 \cdot (-16.7)$ -100.2
33. $26.474 - 14.527$ 11.947	34. $-2.1 + 3.78$ 1.68	35. $-6.15 \div (-8.2)$ 0.75	36. $-12.8 \cdot (-4.88)$ 62.464

Find the sum, difference, product, or quotient. Write your answer in simplest form.

37. $15\frac{1}{2} + 15\frac{1}{4}$ $30\frac{3}{4}$	38. $18\frac{11}{20} - 17\frac{1}{2}$ $1\frac{1}{20}$	39. $3\frac{3}{7} \div 5\frac{1}{3}$ $\frac{9}{14}$	40. $4\frac{1}{2} \cdot 2\frac{2}{5}$ $10\frac{4}{5}$
41. $3\frac{1}{3} - 5\frac{1}{9}$ $-1\frac{7}{9}$	42. $5 \cdot (-1\frac{2}{5})$ -7	43. $-7\frac{3}{5} + (-3\frac{5}{6})$ $-11\frac{13}{30}$	44. $-2\frac{1}{12} \div \frac{3}{8}$ $-5\frac{5}{9}$
45. $9 \div (-4\frac{1}{2})$ -2	46. $-18 + 3\frac{4}{5}$ $-14\frac{1}{5}$	47. $2\frac{5}{6} \cdot (-2\frac{2}{3})$ $-7\frac{5}{9}$	48. $-4\frac{7}{10} - 3\frac{2}{5}$ $-8\frac{1}{10}$

Evaluate the numerical expression. Be sure to use the order of operations!

49. $78 + (-2) \cdot (-56)$ 190	50. $-65 + \frac{6}{-3} + 40$ -27	51. $-94 - [2 - 3(24 - 12)]$ -60	52. $43 + (-23) - (-57)$ 77
53. $-15 - (-11) + 5 \cdot (-4)^3$ -324	54. $-26 - (-64) + (-3)^4$ 119	55. $-84 \div 4 + (-20)$ -41	56. $-56 + (-50) + (-7) \cdot (-9)$ -43
57. $-7.6 - 3 + 2.1 \cdot (-8)$ -27.4	58. $-\frac{2}{3} + \frac{5}{6} \div \frac{1}{2}$ 1	59. $-8 + 3(-2.7 + 4.23)$ -3.41	60. $-3\frac{1}{2} \cdot (-2\frac{3}{4}) + (-4\frac{1}{4})$ $5\frac{3}{8}$

Evaluate the algebraic expression for $a = -12$, $b = 6$, $c = -4$, and $d = 3$.

61. $a - b + c$ -22	62. $b - cd$ 18	63. $b(cd - a)$ 0
64. $\frac{b}{c} - d$ $-4\frac{1}{2}$	65. $bd + ac$ 66	66. $\frac{a}{d} + c^2$ 12

Solve the one-step equation.

ANSWER KEY

67. $19 + j = -34$ $j = -53$	68. $m - 26 = 13$ $m = 39$	69. $\frac{x}{5} = -3$ $x = -15$	70. $12f = 216$ $f = 18$
71. $g - (-31) = -7$ $g = -38$	72. $\frac{h}{9} = 13$ $h = 117$	73. $b + (-3) = -9$ $b = -6$	74. $-4w = -280$ $w = 70$

Solve the two-step equation.

75. $5m - 3 = 27$ $m = 6$	76. $7 + \frac{y}{2} = -3$ $y = -20$	77. $4 + 3r = -8$ $r = -4$	78. $\frac{1}{2}p - 4 = 7$ $p = 22$
79. $\frac{k+8}{3} = -2$ $k = -14$	80. $\frac{f}{5} - (-13) = 12$ $f = -5$	81. $-15 - \frac{g}{3} = -5$ $g = -30$	82. $-8 + 4m = 2$ $m = 25$
83. $-18 - \frac{3}{4}v = 3$ $v = -28$	84. $\frac{-5+n}{4} = -1$ $n = 1$	85. $3.5m + 0.75 = -6.25$ $m = -2$	86. $2y + 3 = 19$ $y = 8$

Convert to a unit rate.

ANSWER KEY

87. $\frac{513 \text{ miles}}{9 \text{ hours}}$ 57 mi/h	88. $\frac{180 \text{ words}}{5 \text{ minutes}}$ 36 words/min	89. $\frac{\$2.53}{8 \text{ oz}}$ \$0.32/oz
--	---	--

Solve the proportion.

90. $\frac{h}{6} = \frac{20}{24}$ h = 5	91. $\frac{5}{7} = \frac{c}{14}$ c = 10	92. $\frac{6}{8} = \frac{21}{b}$ b = 28	93. $\frac{30}{j} = \frac{26}{39}$ j = 45
94. $\frac{5}{k} = \frac{15}{20}$ k = $6\frac{2}{3}$	95. $\frac{32}{112} = \frac{a}{14}$ a = 4	96. $\frac{16}{7} = \frac{18}{g}$ g = 7.875	97. $\frac{w}{60} = \frac{15}{200}$ w = 4.5

Use a proportion to solve the word problem.

98. A cookie recipe calls for 2 eggs and 3 cups of flour. You only have 1 egg, so you have to cut the recipe. How much flour should you use? 1.5 cups of flour	99. Jack can run 2 miles in 15 minutes. At that rate, how far would you expect him to run in an hour? 8 miles	100. Sue read 15 pages of her book in 25 minutes. At that rate, how long will it take her to read the next 10 pages? 16. $\bar{6}$ min (16 min, 40 sec)	101. The ratio of cats to dogs at the park was 1:4. If there were 12 dogs, how many cats were at the park? 3 cats
102. If 2 pounds of apples cost \$2.60, how much would 5 pounds of apples cost? \$6.50	103. If you burn 184 calories running 2 miles, how many calories would you burn if you run 5 miles? 460 calories	104. In a shipment of 300 parts, there are 12 defective parts. How many defective parts would you expect to find in a shipment of 1,000 parts? 40 defective parts	105. The ratio of 12-year-olds to 13-year-olds in Mr. Wu's class is 5:3. If there are 24 students in the class, how many students are 13 years old? 9 students

Solve the percent problem.

ANSWERS

106. Find 15% of 85. 12.75	107. 6 is 75% of what number? 8	108. 40 is what percent of 320? 12.5%	109. What is 20% of 45? 9
110. 70 is what percent of 350? 20%	111. Find 33.3% of 81. 27	112. 9 is 45% of what number? 20	113. What percent of 60 is 12? 20%
114. 5% of the lights on the light string are out. If there are 100 lights on the string, how many are out? 5 lights	115. There were 27 students in Jerome's class last year. This year there are 30 students in his class. Find the percent of change. 11.1% increase	116. A \$58 camera is on sale for 20% off. Find the sale price. \$46.40	117. A \$60 camera is on sale for \$50. Find the percent of change. 16.6% decrease
118. Find the total price of a \$14.00 shirt including the 7% sales tax. \$14.98	119. How much simple interest is earned after 10 years if \$200 is put in an account with a 1.25% interest rate? \$25	120. Your bill at a diner comes to \$45. If you want to leave the waitress a 20% tip, how much money should you give her? \$9	121. Find the final price of a \$58 video game that is on sale for 15% off, after the 6.5% sales tax is included. \$52.50

A bag of marbles contains 8 blue marbles, 6 red marbles, and 4 green marbles. Find the probability of each event if you choose marbles without looking in the bag.

122. P(green)	123. P(red)	124. P(blue)	125. You pick a marble, <u>replace it</u> , and then pick another. Find P(blue, blue).
$\frac{2}{9}$	$\frac{1}{3}$	$\frac{4}{9}$	$\frac{16}{81}$
126. You pick a marble, <u>replace it</u> , and then pick another. Find P(red, green).	127. You pick a marble, <u>do not replace it</u> , and then pick another. Find P(blue, blue).	128. You pick a marble, <u>do not replace it</u> , and then pick another. Find P(red, green).	129. You pick a marble, <u>do not replace it</u> , and then pick another. Find P(green, green).
$\frac{2}{27}$	$\frac{28}{153}$	$\frac{4}{51}$	$\frac{2}{51}$

Identify the relationship between $\angle 1$ and $\angle 2$.

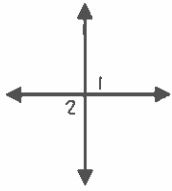
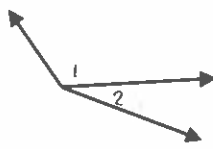
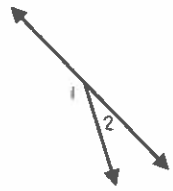
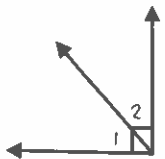
130. 	131. 	132. 	133. 
vertical angles	adjacent angles	supplementary angles	complementary angles

Find the value of x .

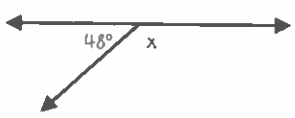
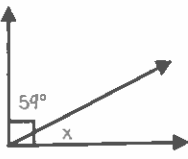
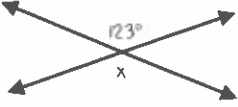
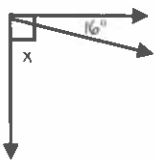
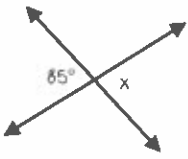
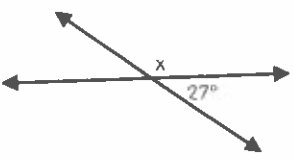
134. 	135. 	136. 
$x = 132^\circ$	$x = 31^\circ$	$x = 123^\circ$
137. 	138. 	139. 
$x = 74^\circ$	$x = 85^\circ$	$x = 153^\circ$

Find the perimeter (or circumference) and area of the given shape. Round to the nearest tenth if necessary.

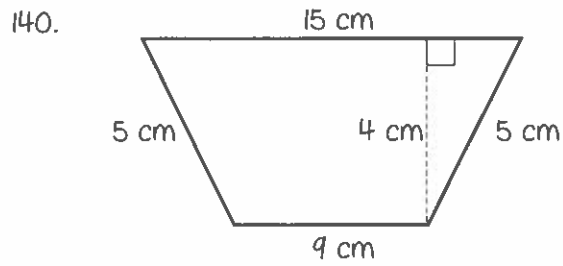

$$P = 34 \text{ cm}$$

$$A = 48 \text{ cm}^2$$

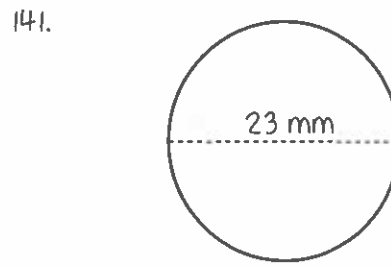

$$C \approx 72.3 \text{ mm}$$

$$A \approx 415.5 \text{ mm}^2$$

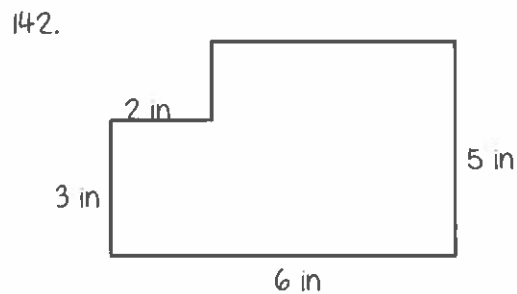

$$P = 22 \text{ in}$$

$$A = 26 \text{ in}^2$$

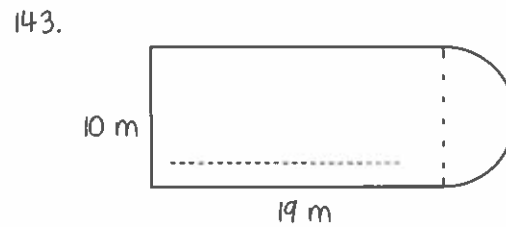

$$P \approx 63.7 \text{ m}$$

$$A \approx 229.3 \text{ m}^2$$

Find the surface area and volume of the given figure. Round to the nearest tenth if necessary.

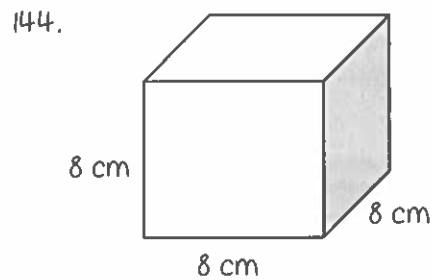

$$SA = 384 \text{ cm}^2$$

$$V = 512 \text{ cm}^3$$

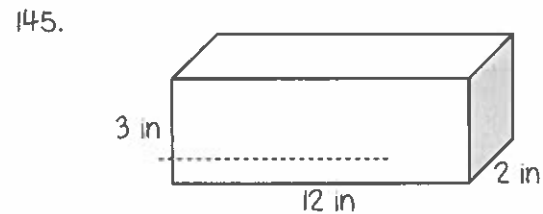

$$SA = 132 \text{ in}^2$$

$$V = 72 \text{ in}^3$$

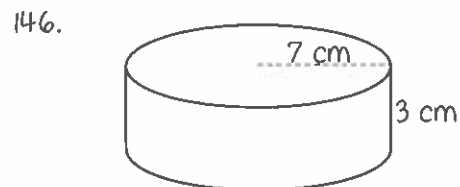

$$SA \approx 439.8 \text{ cm}^2$$

$$V \approx 461.8 \text{ cm}^3$$

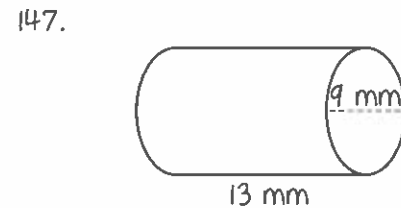

$$SA \approx 494.8 \text{ mm}^2$$

$$V \approx 827.0 \text{ mm}^3$$



**Rising
8th**

**Summer
Enrichment Packet**

Week 6 → Unit 6 Refresh → EXPRESSIONS AND EQUATIONS

<p>Remember!</p>	<p>When solving one step equations, use inverse operations to isolate the variable (aka solve)</p>
<p>Helpful Vocabulary →</p> <ul style="list-style-type: none"> → Variable <ul style="list-style-type: none"> ◆ A letter or symbol that represents an unknown value → Coefficient <ul style="list-style-type: none"> ◆ A number that is multiplied by a variable → Solution <ul style="list-style-type: none"> ◆ The answer / value → Expression <ul style="list-style-type: none"> ◆ Mathematical statement containing terms without an equal sign → Inverse <ul style="list-style-type: none"> ◆ The opposite 	<ul style="list-style-type: none"> → Equivalent <ul style="list-style-type: none"> ◆ Same value → Equivalent expressions <ul style="list-style-type: none"> ◆ Two expressions that share the same value → Distributive property <ul style="list-style-type: none"> ◆ Multiplying the outside terms by all terms inside the parentheses → Equation <ul style="list-style-type: none"> ◆ Mathematical statement containing terms with an equal sign → Exponents <ul style="list-style-type: none"> ◆ The number of times a number is multiplied by itself

(1) Match each equation to **one** of the diagrams. (*the diagrams will be used more than once!*)

- (a) $x + 3 = 9$
- (b) $3 \cdot x = 9$
- (c) $9 = 3 \cdot x$
- (d) $3 + x = 9$
- (e) $x = 9 - 3$
- (f) $x = 9 \div 3$
- (g) $x + x + x = 9$

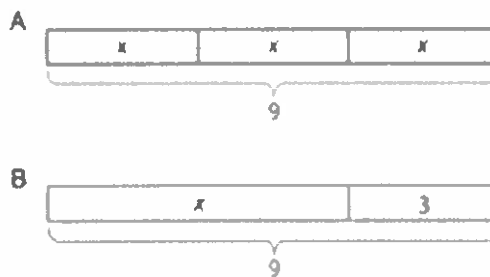

(2) Select **all** true equations.

- (a) $5 + 0 = 0$
- (b) $15 \cdot 0 = 0$
- (c) $1.4 + 2.7 = 4.1$
- (d) $\frac{2}{3} \cdot \frac{5}{9} = \frac{7}{12}$
- (e) $4\frac{2}{3} = 5 - \frac{1}{3}$

(3) Match each equation with a solution from the list.

(a) $2a = 2.6$

(b) $b + 2 = 4.6$

(c) $c \div 2 = 4.6$

(d) $d - 2 = 4.6$

(e) $e + \frac{3}{8} = 2$

(f) $\frac{1}{8}f = 3$

(g) $g \div \frac{8}{5} = 1$

(a) $\frac{8}{5}$

(b) $1\frac{5}{8}$

(c) 1.3

(d) 2.6

(e) 6.6

(f) 9.2

(g) 24

(4) Select **all** the equations that describe each situation, **then** find the solution.

(a) Ary's backpack weighs 3 pounds less than Leia's backpack. Leia's backpack weighs 14 pounds. How much does Ary's backpack weigh?

(i) $x + 3 = 14$

(ii) $3x = 14$

(iii) $x = 14 - 3$

(iv) $x = 14 \div 3$

(b) Each notebook contains 60 sheets of paper. Emmett has 4 notebooks. How many sheets of paper does Emmett have?

(i) $y = 60 \div 5$

(ii) $y = 5 \cdot 60$

(iii) $\frac{y}{5} = 60$

(iv) $5y = 60$

(6) Solve each equation.

(a) $2x = 5$

(b) $y + 1.8 = 14.7$

(c) $6 = \frac{1}{2}z$

(e) $2t = 10$

(d) $3\frac{1}{4} = \frac{1}{4} + w$

(8) Select **all** the expressions that represent the area of the large, outer rectangle.

- (a) $5(2 + 4)$
- (b) $5 \cdot 2 + 4$
- (c) $5 \cdot 2 + 5 \cdot 4$
- (d) $5 \cdot 2 \cdot 4$
- (e) $5 + 2 + 4$
- (f) $5 \cdot 6$

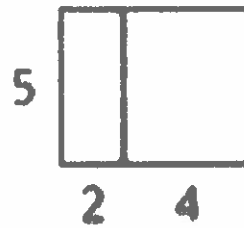

(9) Select **all** the expressions that represent the large rectangle's total area.

- (a) $3(5 + b)$
- (b) $5(b + 3)$
- (c) $5b + 15$
- (d) $15 + 5b$
- (e) $3 \cdot 5 + 3b$



(10) Select **all** the expressions that are equal to: $3 \cdot 3 \cdot 3 \cdot 3 \cdot 3$

(a) $3 \cdot 5$

(b) 3^5

(c) $3^4 \cdot 3$

(d) $5 \cdot 3$

(e) 5^3

(11) Evaluate each expression.

(a) $7 + 2^3$

(c) $20 - 2^4$

(b) $9 \cdot 3^1$

(d) $6^2 \cdot 2$

(12) Solve using inverse operations.

(a) $3x = 15$

(c) $\frac{x}{7} = 6$

(b) $2 + y = 7$

(d) $y - 18 = 10$

Week 7 → Unit 7 Refresh → RATIONAL NUMBERS

<p>Helpful Vocabulary →</p> <ul style="list-style-type: none">→ Positive number<ul style="list-style-type: none">◆ A number that is greater than zero→ Negative number<ul style="list-style-type: none">◆ A number that is less than zero→ Opposite numbers<ul style="list-style-type: none">◆ Two numbers are opposite if they are the same distance from 0 and on different sides of the number line→ Rational number<ul style="list-style-type: none">◆ A fraction or the opposite of a fraction	<ul style="list-style-type: none">→ Sign<ul style="list-style-type: none">◆ The sign of any number that is not 0 is either positive or negative→ Absolute value<ul style="list-style-type: none">◆ The distance a number is from 0→ Inequality<ul style="list-style-type: none">◆ A comparison between expressions where the values are not equivalent→ Quadrant<ul style="list-style-type: none">◆ The coordinate plane is divided into 4 regions called quadrants◆ Numbered using roman numerals
---	--

(1) Is a temperature of -12 degrees warmer or colder than a temperature of -18 degrees?

(2) Is an elevation of -20 feet closer or farther from the surface of the ocean than an elevation of -8 feet?

(3) It was 8 degrees at nightfall. The temperature dropped 20 degrees by midnight. What was the temperature at midnight?

(4) A diver is 15 feet below sea level. After he swims up 5 feet toward the surface, what is his elevation?

(5) For each number, name its opposite.

(a) -7

(d) 0.8

(b) 21

(e) 0

(c) -14.4

(f) -8,007

(6) Draw a number line & plot the following points:

- -1
- The opposite of -1
- -4
- The opposite of -4

(7) Decide whether each inequality statement is **TRUE** or **FALSE**.

(a) $-4 > 2$

(c) $-18 > -15$

(b) $3 > -5$

(d) $-12.5 < -12$

(8) State whether each situation describes a **positive** or **negative** relationship.

(a) Aymen's puppy gained 9 pounds

(b) The aquarium leaked 3 gallons of water

(c) Riean received a gift of \$40

(d) Will gave a gift of \$25

(e) A climber descended 50 feet

Week 8 → Unit 8 Refresh → DATA SETS AND DISTRIBUTIONS

<p>Helpful Vocabulary →</p> <ul style="list-style-type: none">→ Numerical data<ul style="list-style-type: none">◆ A set of data that has values that are numbers→ Categorical data<ul style="list-style-type: none">◆ A set of data that has values that are words instead of numbers→ Dot plot<ul style="list-style-type: none">◆ A way to represent data on a number line	<ul style="list-style-type: none">→ Histogram<ul style="list-style-type: none">◆ A way to represent data on a number line◆ Data values are grouped in ranges◆ The height of the bar shows how many data values are in that group→ Average<ul style="list-style-type: none">◆ The mean is one way to measure
--	--

- ◆ Each time a value appears in the data set, we put another dot above that number on the number line

→ Statistical question

- ◆ Can be answered by collecting data that has variability
- ◆ Some examples
 - How many minutes do the sixth grade students spend on hw each week?
 - What is the typical bedtime of a sixth grade student?
 - How many pets does a sixth grade student have?

→ Variability

- ◆ Having different values

→ Distribution

- ◆ Tells how many times each value occurs in a data set

→ Frequency

- ◆ How many times a value occurs in a data set

→ Center

- ◆ A value in the middle of the distribution

→ Spread

- ◆ Tells how far apart the values are

→ Mode

- ◆

→ Median

- ◆ One way to measure center
- ◆ The middle number when the data set is listed in order

→ Mean

- ◆ The mean is one way to measure the center of a data set. We can think of it as a balance point. For example, for the data set 7, 9, 12, 13, 14, the mean is 11.
- ◆ Aka "average"

the center of a data set. We can think of it as a balance point. For example, for the data set 7, 9, 12, 13, 14, the mean is 11.

- ◆ Aka "mean"

→ Measures of center

- ◆ A value that seems typical for a data distribution

→ Mean absolute deviation (MAD)

- ◆ The mean absolute deviation is one way to measure how spread out a data set is. Sometimes we call this the MAD. For example, for the data set 7, 9, 12, 13, 14, the MAD is 2.4. This tells us that these travel times are typically 2.4 minutes away from the mean, which is 11.

→ Range

- ◆ The distance between the smallest and largest values in a data set

→ Quartile

- ◆ Numbers that divide a data set into four sections that each have the same number of values

→ Interquartile range (IQR)

- ◆ One way to measure how spread out a data set is
- ◆ We subtract the first quartile from the third quartile

→ Box plot

- ◆ One way to represent data on a number line
- ◆ Data is divided into four sections
- ◆ The sides of the box represent the first and third quartiles
- ◆ The line inside the box represents the median
- ◆ The lines outside the box connect to the minimum and maximum values

(1) For each situation, decide whether or not it would produce numerical or categorical data. Put a "check" in the column that corresponds to your answer.

Situation	Categorical Data?	Numerical Data?
What is your favorite vegetable?		
Have you been to the capital of your state?		
How old is the youngest person in your family?		
What is the first letter of your name?		
How many hours of each day do you spend outdoors?		
What is your favorite breakfast cereal?		
How did you get to school this morning?		
How many different teachers do you have?		
What is the last thing you ate or drank?		
How many minutes did it take you to get ready this morning - from waking up to leaving for school?		

(1) Ms. Kildeery asked 10 students at her school how much time, in minutes, it takes them to get home from school. Determine if **each** of these dot plots **could** be used to represent the data Ms. Kildeery collected. Explain your reasoning.



(2) Here is a histogram that summarizes the lengths, in feet, of a group of female sharks. Select **ALL** the statements that are true, according to the histogram.

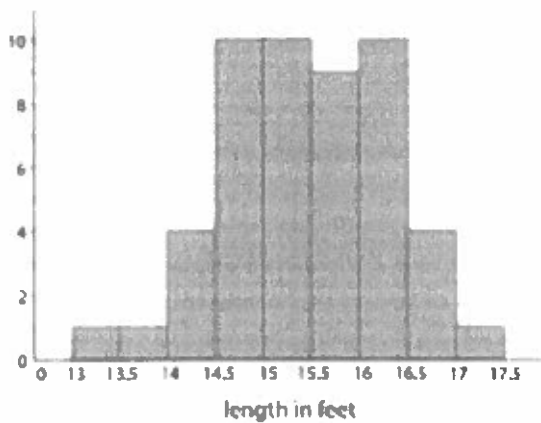

- (a) A total of 9 sharks were measured.
- (b) A total of 50 sharks were measured.
- (c) The longest shark that was measured was 10 feet long.
- (d) Most of the sharks measured were over 16 feet long.
- (e) Two of the sharks measured were less than 14 feet long.

(3) Sadie recorded the number of attempts it took each of 12 of their classmates to successfully throw a ball into a basket. Make a dot plot of the data.

1	2	1	3	1	4	4	3	1	2	5	2
---	---	---	---	---	---	---	---	---	---	---	---

(4) Match the histograms below to the dot plots that represent the same set.

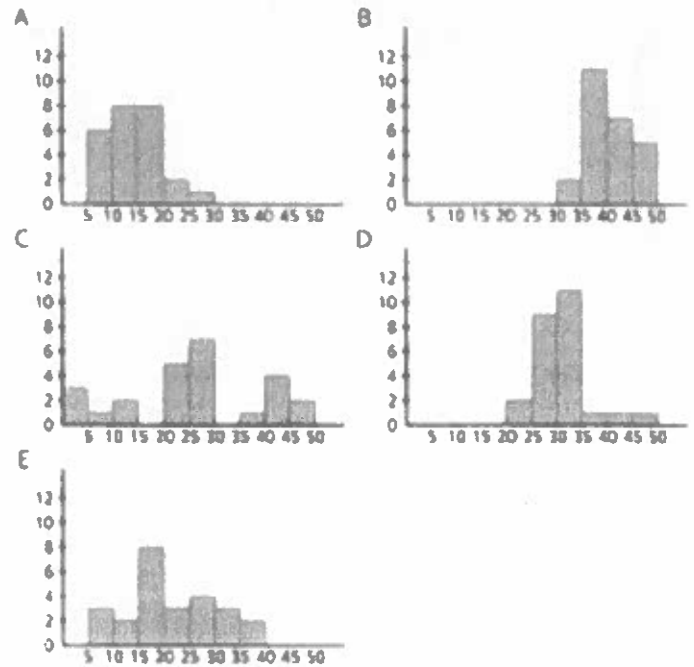
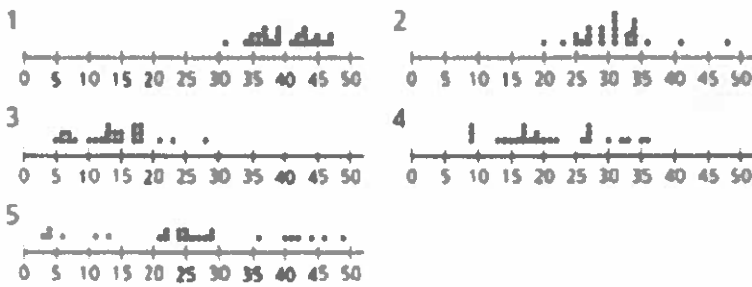

Want more practice??

- There is multiplication & division practice available!
- You can also access IXL all summer long!

Want more of a challenge??

- There is also a challenge packet available!
- If you forgot to get one at the end of the school year, email Ms. Tucker (gtucker@epsd.us) for a virtual copy!

Enjoy the rest of your summer!!